

# INSTALLATION INSTRUCTIONS

# NI TB-2634

## 4 × 32 2-Wire Terminal Block for the NI PXI-2529

このドキュメントには、日本語ページも含まれています。

This document describes how to install and connect signals to the National Instruments TB-2634 terminal block. Refer to the *NI Switches Getting Started Guide* to determine when to install the NI TB-2634.

## Introduction

---

The NI TB-2634 terminal block installs in front of the NI PXI-2529 switch module and has ribbon cable headers that provide access to the rows and columns of the matrix. Connections for the trigger input and trigger output signals also are available.



**Caution** This terminal block is rated for Measurement Category I and intended to carry signal voltages no greater than 150 V. This module can withstand up to 800 V impulse voltage. Do *not* use this module for connection to signals or for measurements within Categories II, III, or IV. Do *not* connect to MAINS supply circuits (for example, wall outlets) of 115 or 230 VAC. Refer to the *Read Me First: Safety and Electromagnetic Compatibility* document for more information on measurement categories.

When module terminals are hazardous voltage LIVE (> 42.4 Vpk/60 VDC), you must ensure that devices and circuits connected to the module are properly insulated from human contact.

## Conventions

---

The following conventions are used in this document:

- » The » symbol leads you through nested menu items and dialog box options to a final action. The sequence **File»Page Setup»Options** directs you to pull down the **File** menu, select the **Page Setup** item, and select **Options** from the last dialog box.



This icon denotes a note, which alerts you to important information.



This icon denotes a caution, which advises you of precautions to take to avoid injury, data loss, or a system crash.

### **bold**

Bold text denotes items that you must select or click in the software, such as menu items and dialog box options. Bold text also denotes parameter names.

### *italic*

Italic text denotes variables, emphasis, a cross-reference, or an introduction to a key concept. Italic text also denotes text that is a placeholder for a word or value that you must supply.

### monospace

Text in this font denotes text or characters that you should enter from the keyboard, sections of code, programming examples, and syntax examples. This font is also used for the proper names of disk drives, paths, directories, programs, subprograms, subroutines, device names, functions, operations, variables, filenames, and extensions.

## 1. Unpack the Terminal Block

---

The terminal block is shipped in an antistatic package to prevent electrostatic discharge (ESD) that can damage several components on the terminal block. To avoid such damage when you handle the terminal block, take the following precautions:



**Caution** *Never* touch the exposed pins of connectors.

- Ground yourself using a grounding strap or by touching a grounded object.
- Touch the antistatic package to a metal part of the chassis before you remove the terminal block from the package.

Remove the terminal block from the package and inspect the terminal block for loose components or any sign of damage. Notify NI if the terminal block appears damaged in any way. Do *not* install a damaged terminal block on a switch module.

Store the terminal block in the antistatic package when not in use.

## 2. Verify the Components

---

Make sure you have the following:

- NI TB-2634 terminal block
- PXI chassis
- NI PXI-2529 switch module
- 1/8 in. flathead screwdriver
- Ribbon cables terminated with  $2 \times 16$ , 0.1 in. pitch sockets



**Note** Refer to the [Accessories](#) section for a list of vendors that supply compatible sockets and ribbon cabling for signal connections.

## 3. Connect Signals

---

To connect signals to the terminal block, complete the following steps while referring to Figure 1.

1. Remove the terminal block top cover screw with a flathead screwdriver.
2. Gently lift the terminal block top cover off the terminal block.
3. Loosen the two screws on the strain-relief bar, leaving plenty of space for the signal cables.
4. Pull the ribbon cables through the strain-relief opening as shown in Figure 1.
5. Connect the safety earth ground to the safety ground lug.
6. Connect each ribbon cable socket to a ribbon cable header. When connecting your signals to the headers, refer to the connection diagram in Figure 2.
7. Remove slack in the ribbon cables by pulling them through the strain-relief bar.
8. Tighten the two screws on the strain-relief bar until the signal wires are secured.
9. Replace the terminal block top cover.
10. Secure the terminal block top cover with the top cover screw.

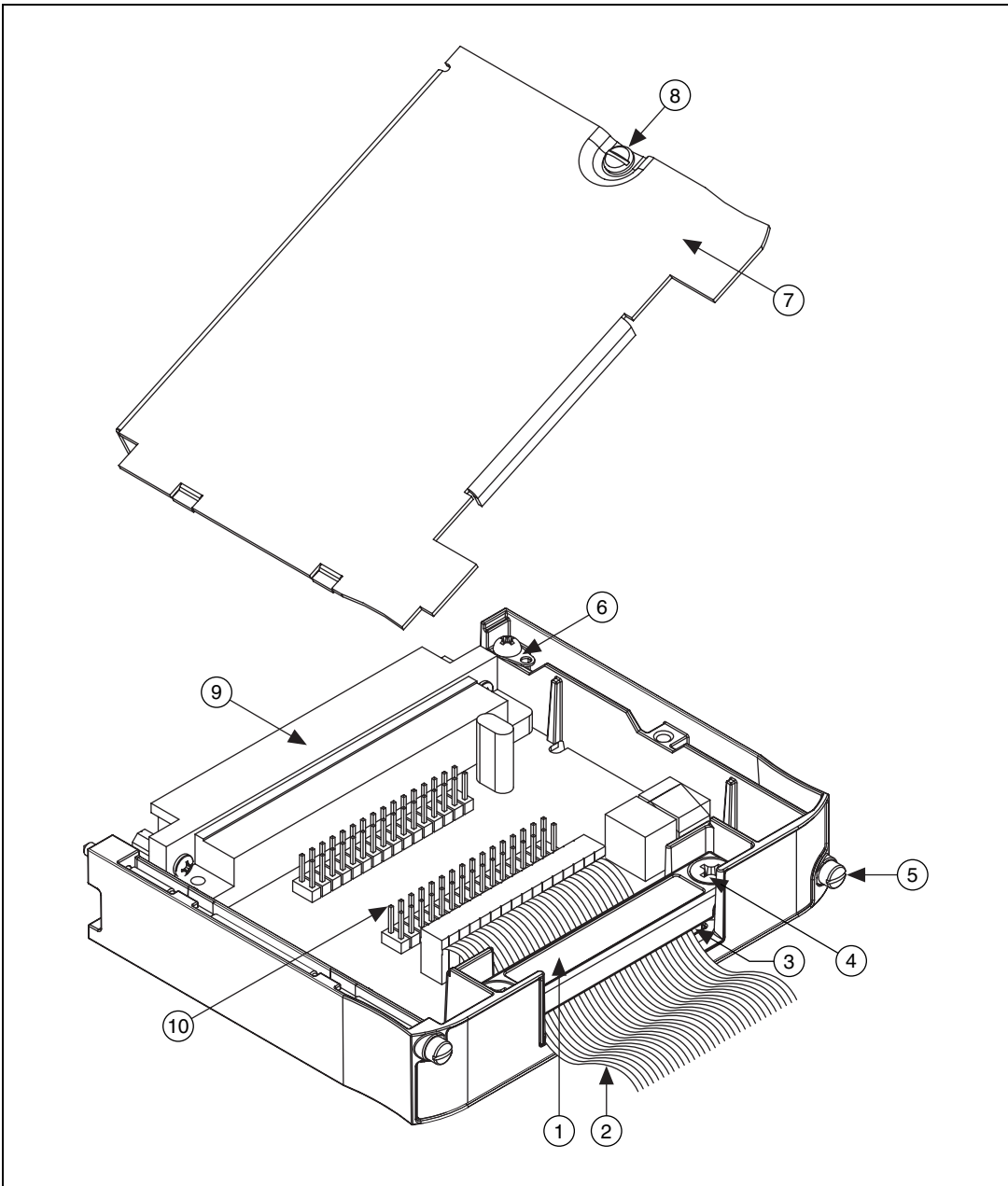

- |                               |                            |
|-------------------------------|----------------------------|
| 1 Strain-Relief Bar           | 6 Safety Ground Lug        |
| 2 Ribbon Cable (not included) | 7 Terminal Block Top Cover |
| 3 Strain-Relief Opening       | 8 Top Cover Screw          |
| 4 Strain-Relief Screw         | 9 Rear Connector           |
| 5 Jackscrew                   | 10 Ribbon Cable Header     |

**Figure 1.** NI TB-2634 Terminal Block

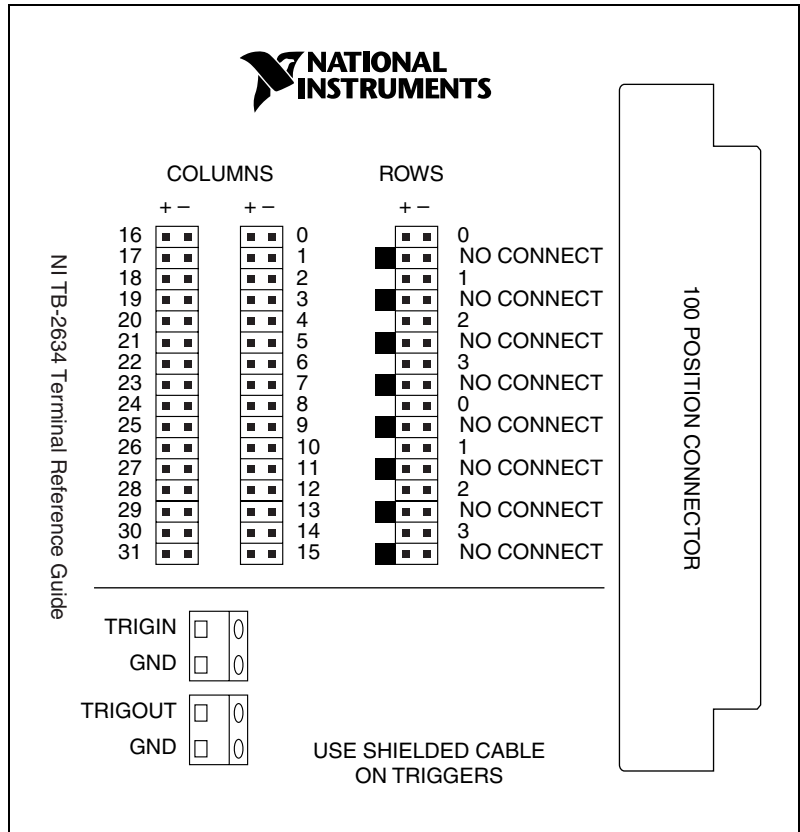
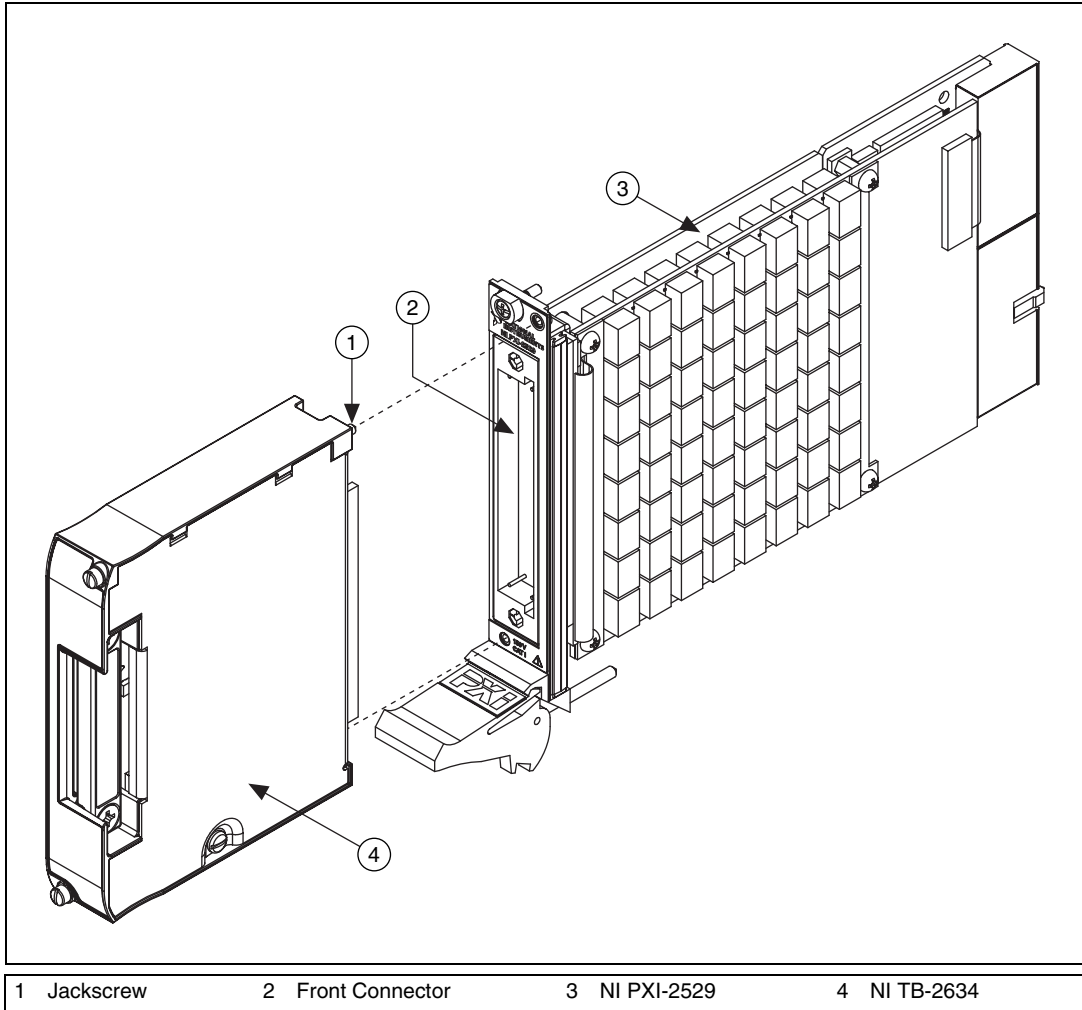

**Figure 2.** NI TB-2634 Terminal Reference

## 4. Install the Terminal Block

To connect the NI TB-2634 terminal block to the NI PXI-2529 front panel, complete the following steps while referring to Figure 3.

1. Connect the NI PXI-2529 front connector to its mating connector on the terminal block.
2. Tighten the top and bottom jackscrews on the terminal block to hold it securely in place. Do *not* overtighten the screws.



**Figure 3.** Installing the NI TB-2634 Terminal Block

# Accessories

---

Refer to Table 1 for vendors of compatible sockets.

**Table 1.** Third-Party Accessories for the NI TB-2634

Accessory	Manufacturer	Manufacturer Part Number
0.1 in. 2 × 16 low-profile ribbon cable socket	Samtec	HCSD-16-01
0.1 in. 2 × 16 ribbon cable assembly	Samtec	IDSD-16 series



**Note** The ribbon cable accessories listed in Table 1 limit the maximum current you can route to 1.5 A.

# Compliance and Certifications

---

## Safety

This product is designed to meet the requirements of the following standards of safety for electrical equipment for measurement, control, and laboratory use:

- IEC 61010-1, EN 61010-1
- UL 61010-1, CSA 61010-1



**Note** For UL and other safety certifications, refer to the product label or visit [ni.com/certification](http://ni.com/certification), search by model number or product line, and click the appropriate link in the Certification column.

## Electromagnetic Compatibility

This product is designed to meet the requirements of the following standards of EMC for electrical equipment for measurement, control, and laboratory use:

- EN 61326 EMC requirements; Minimum Immunity
- EN 55011 Emissions; Group 1, Class A
- CE, C-Tick, ICES, and FCC Part 15 Emissions; Class A



**Note** For EMC compliance, operate this device with shielded cables.

## CE Compliance

This product meets the essential requirements of applicable European Directives, as amended for CE marking, as follows:

- 2006/95/EC; Low-Voltage Directive (safety)
- 2004/108/EC; Electromagnetic Compatibility Directive (EMC)



**Note** Refer to the Declaration of Conformity (DoC) for this product for any additional regulatory compliance information. To obtain the DoC for this product, visit [ni.com/certification](http://ni.com/certification), search by model number or product line, and click the appropriate link in the Certification column.

## Environmental Management

National Instruments is committed to designing and manufacturing products in an environmentally responsible manner. NI recognizes that eliminating certain hazardous substances from our products is beneficial not only to the environment but also to NI customers.

For additional environmental information, refer to the *NI and the Environment* Web page at [ni.com/environment](http://ni.com/environment). This page contains the environmental regulations and directives with which NI complies, as well as other environmental information not included in this document.

## Waste Electrical and Electronic Equipment (WEEE)



**EU Customers** At the end of their life cycle, all products *must* be sent to a WEEE recycling center. For more information about WEEE recycling centers and National Instruments WEEE initiatives, visit [ni.com/environment/weee.htm](http://ni.com/environment/weee.htm).

## 电子信息产品污染控制管理办法（中国 RoHS）



**中国客户** National Instruments 符合中国电子信息产品中限制使用某些有害物质指令 (RoHS)。关于 National Instruments 中国 RoHS 合规性信息，请登录 [ni.com/environment/rohs\\_china](http://ni.com/environment/rohs_china)。(For information about China RoHS compliance, go to [ni.com/environment/rohs\\_china](http://ni.com/environment/rohs_china).)