

## CALIBRATION PROCEDURE

# NI 9210

## 4-Channel, 14 S/s Aggregate, $\pm 80$ mV C Series Temperature Input Module

This document contains the verification and adjustment procedures for the NI 9210. For more information about calibration solutions, visit [ni.com/calibration](http://ni.com/calibration).

## Software

---

Calibrating the NI 9210 requires the installation of NI-DAQmx 16.1 or later on the calibration system. You can download NI-DAQmx from [ni.com/downloads](http://ni.com/downloads). NI-DAQmx supports LabVIEW, LabWindows™/CVI™, C++, and .NET. When you install NI-DAQmx, you only need to install support for the application software that you intend to use. Visit [ni.com/info](http://ni.com/info) and enter Info Code `9210CalibrationExample`.

## Documentation

---

Consult the following documents for information about the NI 9210, NI-DAQmx, and your application software. All documents are available on [ni.com](http://ni.com) and help files install with the software.

*NI cDAQ-9174/9178 USB Chassis Quick Start*  
NI-DAQmx installation and hardware setup

*NI 9210 Datasheet*  
NI 9210 specific information, specifications, and calibration interval

*NI-DAQmx Readme*  
Operating system and application software support in NI-DAQmx

*LabVIEW Help*  
LabVIEW programming concepts and reference information about NI-DAQmx VIs and functions

## NI-DAQmx C Reference Help

Reference information for NI-DAQmx C functions and NI-DAQmx C properties

## NI-DAQmx .NET Help Support for Visual Studio

Reference information for NI-DAQmx .NET methods and NI-DAQmx .NET properties, key concepts, and a C enum to .NET enum mapping table

# Test Equipment

---

Table 1 lists the equipment recommended for the performance verification and adjustment procedures. If the recommended equipment is not available, select a substitute using the requirements listed in Table 1.

**Table 1.** Recommended Equipment

Equipment	Recommended Model	Requirements
Calibrator	Fluke 5522A locked in the 3.3 V range	A high-precision voltage source with $< 7 \mu\text{V}$ of uncertainty at 75 mV and $< 2 \mu\text{V}$ of uncertainty at 0 V and an output impedance $< 5 \Omega$ .
Chassis	NI cDAQ-9178	—
Mini TC x4	Omega SMPW-U-M	U Type

# Test Conditions

---

The following setup and environmental conditions are required to ensure the NI 9210 meets published specifications.

- Keep connections to the NI 9210 as short as possible. Long cables and wires act as antennae, picking up extra noise that can affect measurements.
- Verify that all connections to the NI 9210 are secure.
- Use shielded copper wire for all cable connections to the NI 9210. Connect the calibrator end of the shield to the guard terminal of the calibrator and the NI 9210 end of the shield to the COM terminal of the NI 9210.
- Maintain an ambient temperature of  $23 \text{ }^\circ\text{C} \pm 5 \text{ }^\circ\text{C}$ .
- Keep relative humidity below 80%.
- Allow a warm-up time of at least 10 minutes to ensure that the NI 9210 measurement circuitry is at a stable operating temperature.

# Initial Setup

---

Complete the following steps to set up the NI 9210.

1. Install NI-DAQmx.
2. Make sure the cDAQ-9178 power source is not connected.
3. Connect the cDAQ-9178 to the system ground.
  - a. Attach a ring lug to a 14 AWG (1.6 mm) wire.
  - b. Connect the ring lug to the ground terminal on the side of the cDAQ-9178 using the ground screw.
  - c. Attach the other end of the wire to the system ground.
4. Install the module in slot 8 of the cDAQ-9178 chassis. Leave slots 1 through 7 of the cDAQ-9178 chassis empty.
5. Connect the cDAQ-9178 chassis to your host computer.
6. Connect the power source to the cDAQ-9178 chassis.
7. Launch Measurement & Automation Explorer (MAX).
8. Right-click the device name and select **Self-Test** to ensure that the module is working properly.

## Verification

---

The following performance verification procedure describes the sequence of operation and test points required to verify the NI 9210 and assumes that adequate traceable uncertainties are available for the calibration references.

### Accuracy Verification

Complete the following procedure to determine the As-Found status of the NI 9210.

1. Set the calibrator to Standby mode (STBY).
2. Connect the NI 9210 to the calibrator as shown in Figure 1.

**Figure 1. Accuracy Verification Connections**

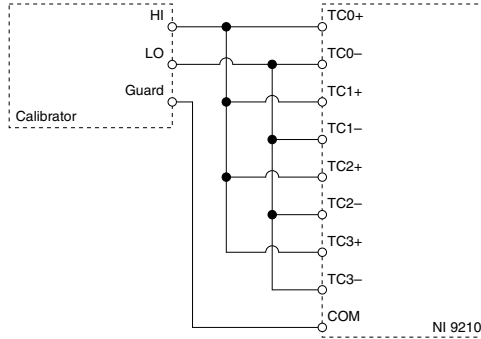

**Note** The calibrator should be ground referenced.

3. Set the calibrator output to a Test Point value indicated in Table 4.
4. Set the calibrator to Operate mode (OPR).
5. Acquire and average samples.
  - a. Create and configure an AI voltage channel according to Table 2.

**Table 2. NI 9210 AI Voltage Channel Configuration**

Input Terminal Configuration	Minimum Value (V)	Maximum Value (V)	Physical Channels	Units	Autozero
Differential	-0.08	0.08	cDAQMod8/ ai0:3	Volts	Every Sample

- b. Configure the AI voltage channel timing according to Table 3.

**Table 3. NI 9210 Timing Configuration**

Samples Per Channel	Sample Mode	Rate (S/s)
100	Finite	7

- c. Start the task.
    - d. Read samples from the NI 9210.
    - e. Average the samples for each channel.
    - f. Clear the task.
6. Compare the average sample for each channel to the test limits in Table 4.

**Table 4. NI 9210 Test Limits**

Test Point		1-Year Limits	
Location	Value (V)	Lower Limit (V)	Upper Limit (V)
Max	0.070000	0.0699587	0.0700413
Mid	0	-0.0000152	0.0000152
Min	-0.070000	-0.0700413	-0.0699587



**Note** Values in Table 4 should be used for calibration verification only. These values only apply under the specific calibration conditions described in this document, and are not to be construed as general operational specifications of the NI 9210. For operational specifications, refer to the most recent NI 9210 datasheet at [ni.com/manuals](http://ni.com/manuals).

7. Set the calibrator to Standby mode (STBY).
8. Repeat steps 3 through 7 for each test point in Table 4.
9. Disconnect the calibrator from the NI 9210.

## Adjustment

The following performance adjustment procedure describes the sequence of operation required to adjust the NI 9210.

### Accuracy Adjustment

Complete the following procedure to adjust the accuracy performance of the NI 9210.

1. Set the calibrator to Standby mode (STBY).
2. Connect the NI 9210 to the calibrator as shown in Figure 1.
3. Set the calibrator output to 0.07 V.
4. Set the calibrator to Operate mode (OPR).
5. Adjust the NI 9210.
  - a. Open a calibration session on the NI 9210.
  - b. Input the external temperature in degrees Celsius.
  - c. Call and configure the NI 9210 adjustment function according to Table 5.

**Table 5. Adjustment Configuration**

Physical Channels	Reference Value
cDAQMod8/ai0:3	0.07

- d. Close the calibration session.
6. Set the calibrator to Standby mode (STBY).
7. Disconnect the calibrator from the NI 9210.

# EEPROM Update

---

When an adjustment procedure is completed, the NI 9210 internal calibration memory (EEPROM) is immediately updated.

If you do not want to perform an adjustment, you can update the calibration date and onboard calibration temperature without making any adjustments by initializing an external calibration, setting the C Series calibration temperature, and closing the external calibration.

## Re-Verification

---

Repeat the Verification section to determine the As-Left status of the device.



**Note** If any test fails Re-Verification after performing an adjustment, verify that you have met the Test Conditions before returning your device to NI. Refer to Worldwide Support and Services for assistance in returning the device to NI.

## Worldwide Support and Services

---

The NI website is your complete resource for technical support. At [ni.com/support](https://ni.com/support), you have access to everything from troubleshooting and application development self-help resources to email and phone assistance from NI Application Engineers.

Visit [ni.com/services](https://ni.com/services) for NI Factory Installation Services, repairs, extended warranty, and other services.

Visit [ni.com/register](https://ni.com/register) to register your NI product. Product registration facilitates technical support and ensures that you receive important information updates from NI.

A Declaration of Conformity (DoC) is our claim of compliance with the Council of the European Communities using the manufacturer's declaration of conformity. This system affords the user protection for electromagnetic compatibility (EMC) and product safety. You can obtain the DoC for your product by visiting [ni.com/certification](https://ni.com/certification). If your product supports calibration, you can obtain the calibration certificate for your product at [ni.com/calibration](https://ni.com/calibration).

NI corporate headquarters is located at 11500 North Mopac Expressway, Austin, Texas, 78759-3504. NI also has offices located around the world. For telephone support in the United States, create your service request at [ni.com/support](https://ni.com/support) or dial 1 866 ASK MYNI (275 6964). For telephone support outside the United States, visit the *Worldwide Offices* section of [ni.com/global](https://ni.com/global) to access the branch office websites, which provide up-to-date contact information, support phone numbers, email addresses, and current events.

Information is subject to change without notice. Refer to the *NI Trademarks and Logo Guidelines* at [ni.com/trademarks](http://ni.com/trademarks) for information on NI trademarks. Other product and company names mentioned herein are trademarks or trade names of their respective companies. For patents covering NI products/technology, refer to the appropriate location: **Help»Patents** in your software, the `patents.txt` file on your media, or the *National Instruments Patent Notice* at [ni.com/patents](http://ni.com/patents). You can find information about end-user license agreements (EULAs) and third-party legal notices in the `readme` file for your NI product. Refer to the *Export Compliance Information* at [ni.com/legal/export-compliance](http://ni.com/legal/export-compliance) for the NI global trade compliance policy and how to obtain relevant HTS codes, ECCNs, and other import/export data. NI MAKES NO EXPRESS OR IMPLIED WARRANTIES AS TO THE ACCURACY OF THE INFORMATION CONTAINED HEREIN AND SHALL NOT BE LIABLE FOR ANY ERRORS. U.S. Government Customers: The data contained in this manual was developed at private expense and is subject to the applicable limited rights and restricted data rights as set forth in FAR 52.227-14, DFAR 252.227-7014, and DFAR 252.227-7015.

© 2017 National Instruments. All rights reserved.

377194A-01 August 3, 2017