

CALIBRATION PROCEDURE

NI 9214

Français Deutsch 日本語 한국어 简体中文
ni.com/manuals

This document contains the verification and adjustment procedures for the National Instruments 9214. For more information about calibration solutions, visit ni.com/calibration.



Note Refer to the *NI TB-9214 Calibration Procedure* on ni.com/manuals for instructions on calibrating the NI TB-9214.

Contents

| | |
|--|----|
| Software..... | 1 |
| Documentation..... | 2 |
| Test Equipment..... | 3 |
| Connecting the NI 9214..... | 4 |
| Test Conditions..... | 4 |
| Initial Setup..... | 5 |
| Verification..... | 5 |
| Voltage Verification..... | 5 |
| CJC Verification..... | 8 |
| Adjustment..... | 10 |
| Voltage and CJC Adjustment..... | 10 |
| EEPROM Update..... | 11 |
| Reverification..... | 11 |
| Accuracy Under Calibration Conditions..... | 12 |
| Where to Go for Support..... | 12 |

Software

Calibrating the NI 9214 requires the installation of NI-DAQmx 9.3 or later on the calibration system. You can download NI-DAQmx from ni.com/downloads. NI-DAQmx supports LabVIEW, LabWindows™/CVI™, ANSI C, and .NET. When you install NI-DAQmx, you only need to install support for the application software that you intend to use.

Documentation

Consult the following documents for information about the NI 9214, NI-DAQmx, and your application software. All documents are available on ni.com and help files install with the software.



NI cDAQ-9174/9178 Quick Start

NI-DAQmx installation and hardware setup



NI 9214 User Guide/Manual and Specifications

NI 9214 specific information, specifications, and calibration interval



NI-DAQmx Readme

Operating system and application software support in NI-DAQmx



LabVIEW Help

LabVIEW programming concepts and reference information about NI-DAQmx VIs and functions



NI-DAQmx C Reference Help

Reference information for NI-DAQmx C functions and NI-DAQmx C properties



NI-DAQmx .NET Help Support for Visual Studio

Reference information for NI-DAQmx .NET methods and NI-DAQmx .NET properties, key concepts, and a C enum to .NET enum mapping table

Test Equipment

Table 1 lists the equipment recommended for the performance verification and adjustment procedures. If the recommended equipment is not available, select a substitute using the requirements listed in Table 1.

Table 1. Recommended Equipment

| Equipment | Recommended Model | Where Used | Requirements |
|----------------------|---|--|---|
| Calibrator | Fluke 5520A locked in the 3.3 V range | Voltage Verification, Adjustment | Use a high-precision voltage source with an accuracy of ≤ 20 ppm when sourcing up to 50 μA . |
| | Fluke 5520A | CJC Verification, Adjustment | Use a high-precision resistance source with an accuracy of ≤ 150 ppm 2-wire compensation. If the resistance source does not have 2-wire compensation, the leadwire resistance must be included in the total resistance source accuracy. |
| Chassis | NI cDAQ-9178 | All | — |
| Connection Accessory | NI CAL-9214 | All | — |

Connecting the NI 9214

The NI CAL-9214 provides connections for 16 thermocouple channels and 3 CJC channels on the NI 9214. Refer to Figure 1 for a pinout of the NI CAL-9214.



Caution Do not connect voltages greater than 10 VDC to the NI CAL-9214.

Figure 1. NI CAL-9214 Pinout

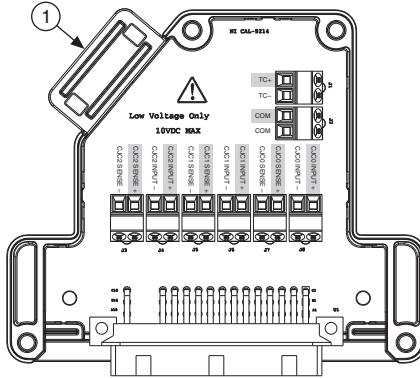

1 Ground Lug (on the bottom side of the NI CAL-9214 enclosure)

Connect the NI CAL-9214 to the NI 9214 front connector as shown in Figure 2. Tighten the two jackscrews on the NI CAL-9214 to hold it securely in place. Do not overtighten the jackscrews.

Figure 2. Installing the NI CAL-9214

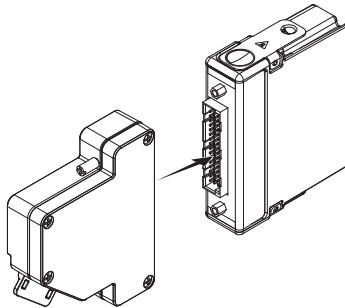

Test Conditions

The following setup and environmental conditions are required to ensure the NI 9214 meets published specifications.

- Keep connections to the NI 9214 as short as possible. Long cables and wires act as antennae, picking up extra noise that can affect measurements.
- Verify that all connections to the NI 9214 are secure.

- Use shielded copper wire for all cable connections to the NI 9214. Use twisted-pairs wire to eliminate noise and thermal offsets.
- Maintain an ambient temperature of $23\text{ }^{\circ}\text{C} \pm 5\text{ }^{\circ}\text{C}$. The NI 9214 temperature will be greater than the ambient temperature.
- Keep relative humidity below 80%.
- Allow a warm-up time of at least 15 minutes to ensure that the NI 9214 measurement circuitry is at a stable operating temperature.

Initial Setup

Complete the following steps to set up the NI 9214.

1. Install NI-DAQmx.
2. Make sure the NI cDAQ-9178 power source is not connected.
3. Connect the NI cDAQ-9178 to the system safety ground.
 - a. Attach a ring lug to a 14 AWG (1.6 mm) wire.
 - b. Connect the ring lug to the ground terminal on the side of the NI cDAQ-9178 using the ground screw.
 - c. Attach the other end of the wire to the system safety ground.
4. Install the module in slot 8 of the NI cDAQ-9178 chassis. Leave slots 1 through 7 of the NI cDAQ-9178 chassis empty.
5. Connect the NI cDAQ-9178 chassis to your host computer.
6. Connect the power source to the NI cDAQ-9178 chassis.
7. Launch Measurement & Automation Explorer (MAX).
8. Right-click the device name and select **Self-Test** to ensure that the module is working properly.

Verification

The following performance verification procedures describe the sequence of operation and test points required to verify the NI 9214 and assume that adequate traceable uncertainties are available for the calibration references.

Voltage Verification

Complete the following procedure to determine the As-Found status of the NI 9214.

1. Loosen the captive screws and remove the top cover from the NI CAL-9214.
2. Connect the calibrator to the NI CAL-9214 according to Figure 3.

Figure 3. Voltage Channel Verification Connections

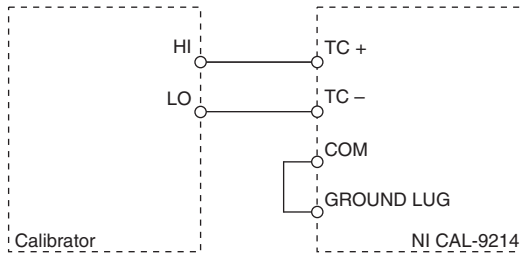

3. Reinstall the top cover on the NI CAL-9214.
4. Connect the NI CAL-9214 to the NI 9214.
5. If using a Fluke 5520A calibrator, lock the voltage range to 3.3 V to reduce loading error.
 - a. Set the output voltage to 2.0 V.
 - b. Press the **3.3 V auto** button to lock the 3.3 V range.
6. Set the calibrator output to a Test Point value indicated in Table 4.
7. Set the calibrator to Operate mode (OPR).
8. Acquire and average samples.
 - a. Create and configure an AI voltage channel on the NI 9214 according to Table 2.

Table 2. NI 9214 Voltage Channel Configuration

| Physical Channels | Input Range (mV) | | Scaled Units | Terminal Configuration | Autozero | OTD |
|-------------------|------------------|--------|--------------|------------------------|--------------|----------|
| | Min | Max | | | | |
| cDAQ1Mod8/air | -78.125 | 78.125 | Volts | Differential | Every Sample | Disabled |

- b. Configure the AI voltage channel timing according to Table 3.

Table 3. NI 9214 Voltage Channel Timing Configuration

| ADC Timing Mode | Sample Mode | Samples to Read | Rate (S/s) |
|-----------------|-------------|-----------------|------------|
| High Resolution | Finite | 8 | 8.5 |
| High Speed | Finite | 130 | 90 |

- c. Start the task.
 - d. Average the readings.
 - e. Clear the task.
9. Compare the average to the limits in Table 4.
10. Set the calibrator to Standby mode (STBY).
11. Repeat steps 6 through 10 for each test point.

12. Repeat steps 6 through 11 for each channel on the NI 9214.

Table 4. NI 9214 Voltage Verification Test Limits for Positive and Negative Test Points

| ADC Timing Mode | Range (mV) | | Test Point | | 1-Year Limits | |
|-----------------|------------|--------|--------------|------------|------------------|------------------|
| | Min | Max | Location | Value (mV) | Lower Limit (mV) | Upper Limit (mV) |
| High Resolution | -78.125 | 78.125 | Negative FS | -70 | -70.0330 | -69.9670 |
| | | | Negative Mid | -35 | -35.0180 | -34.9820 |
| | | | Positive Mid | 35 | 34.9820 | 35.0180 |
| | | | Positive FS | 70 | 69.9670 | 70.0330 |
| High Speed | -78.125 | 78.125 | Negative FS | -70 | -70.0580 | -69.9420 |
| | | | Negative Mid | -35 | -35.0370 | -34.9630 |
| | | | Positive Mid | 35 | 34.9630 | 35.0370 |
| | | | Positive FS | 70 | 69.9420 | 70.0580 |



Note The test limits listed in Table 4 are derived using the values in Table 11.

13. Loosen the captive screws and remove the top cover from the NI CAL-9214.
14. Disconnect the calibrator from the NI CAL-9214.
15. Short the TC+ and TC- terminals on the NI CAL-9214 together.
16. Reinstall the top cover on the NI CAL-9214.
17. Acquire and average samples.
 - a. Create and configure an AI voltage task on the NI 9214 according to Table 2.
 - b. Configure the AI voltage channel timing according to Table 3.
 - c. Start the task.
 - d. Average the readings.
 - e. Clear the task.

18. Compare the average to the limits in Table 5.

Table 5. NI 9214 Voltage Verification Test Limits for Zero Test Points

| ADC Timing Mode | Range (mV) | | Test Point | | 1-Year Limits | |
|-----------------|------------|--------|------------|------------|------------------|------------------|
| | Min | Max | Location | Value (mV) | Lower Limit (mV) | Upper Limit (mV) |
| High Resolution | -78.125 | 78.125 | Zero | 0 | -0.0027 | 0.0027 |
| High Speed | -78.125 | 78.125 | Zero | 0 | -0.0160 | 0.0160 |



Note The test limits listed in Table 5 are derived using the values in Table 11.

19. Repeat steps 17 through 18 for each test point.
20. Repeat steps 17 through 19 for each channel on the NI 9214.
21. Remove the NI CAL-9214 from the NI 9214.
22. Loosen the captive screws and remove the top cover from the NI CAL-9214.
23. Disconnect the short from the NI CAL-9214.

CJC Verification

Complete the following procedure to determine the As-Found status of the NI 9214.

1. Loosen the captive screws and remove the top cover from the NI CAL-9214.
2. Connect the calibrator to the NI CAL-9214 according to Figure 4.

Figure 4. CJC Channel Verification Connections

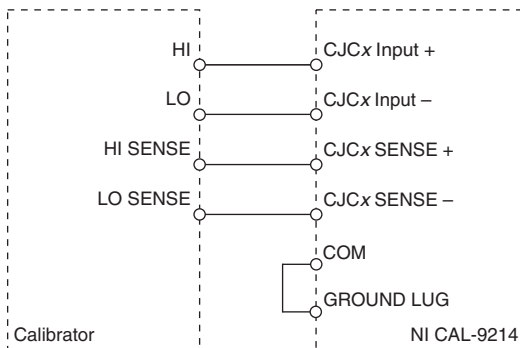

3. Reinstall the top cover on the NI CAL-9214.
4. Connect the NI CAL-9214 to the NI 9214.
5. Set the calibrator to 2-Wire Compensation mode.
6. Set the calibrator output to a Test Point value indicated in Table 8.

7. Set the calibrator to Operate mode (OPR).
8. Acquire and average samples.
 - a. Create and configure an AI voltage channel on the NI 9214 according to Table 6.

Table 6. NI 9214 CJC Channel Verification Configuration

| Physical Channels | Input Range (V) | | Scaled Units |
|--------------------|-----------------|-----|--------------|
| | Min | Max | |
| cDAQ1Mod8/_cjtempv | -2.5 | 2.5 | Volts |

- b. Configure the AI voltage channel timing according to Table 7.

Table 7. NI 9214 CJC Channel Verification Configuration

| ADC Timing Mode | Sample Mode | Samples to Read | Rate (S/s) |
|-----------------|-------------|-----------------|------------|
| High Resolution | Finite | 8 | 8.5 |
| High Speed | Finite | 130 | 90 |

- c. Start the task.
 - d. Average the readings.
 - e. Clear the task.
9. Perform the following calculation to scale the voltage average to resistance.

$$Resistance = 20000 \times \frac{Voltage}{(2.5 - Voltage)}$$

10. Compare the calculated resistance to the limits in Table 8.
11. Set the calibrator to Standby mode (STBY).
12. Repeat steps 6 through 11 for each test point.
13. Remove the NI CAL-9214 from the NI 9214.
14. Loosen the captive screws and remove the top cover from the NI CAL-9214.
15. Disconnect the calibrator from the NI CAL-9214.
16. Repeat steps 2 through 15 for each CJC channel on the NI 9214.

Table 8. NI 9214 Offset Test Limits

| ADC Timing Mode | Test Point | | 1-Year Limits | |
|-----------------|------------|-----------|-----------------|-----------------|
| | Location | Value (Ω) | Lower Limit (Ω) | Upper Limit (Ω) |
| High Resolution | Offset | 1000 | 997.9 | 1002.1 |
| | Gain 1 | 19000 | 18953.0 | 19047.0 |
| | Gain 2 | 100000 | 99470.0 | 100530.0 |

Table 8. NI 9214 Offset Test Limits (Continued)

| ADC Timing Mode | Test Point | | 1-Year Limits | |
|-----------------|------------|--------------------|--------------------------|--------------------------|
| | Location | Value (Ω) | Lower Limit (Ω) | Upper Limit (Ω) |
| High Speed | Offset | 1000 | 997.3 | 1002.7 |
| | Gain 1 | 19000 | 18952.0 | 19048.0 |
| | Gain 2 | 100000 | 99460.0 | 100540.0 |



Note The test limits in Table 8 are derived using the values in Table 11.

Adjustment

The following performance adjustment procedure describes the sequence of operation required to adjust the NI 9214.

Voltage and CJC Adjustment

Complete the following procedure to adjust the temperature measurement accuracy performance of the NI 9214.

1. Loosen the captive screws and remove the top cover from the NI CAL-9214.
2. Connect the calibrator to the NI CAL-9214 according to Figure 3.
3. Reinstall the top cover on the NI CAL-9214.
4. Connect the NI CAL-9214 to the NI 9214.
5. Initialize a calibration session on the NI 9214. The default password is NI.
6. Adjust the NI 9214 voltage.
 - a. Input the external temperature in degrees Celsius using the set temperature C Series function.
 - b. Call the NI 9214 get C Series adjustment points function to obtain an array of recommended calibration voltages for the NI 9214.
 - c. If using the Fluke 5520A calibrator, lock the voltage range to 3.3 V to reduce loading error.
 - d. Set the calibrator to a reference value determined by the array of adjustment points.
 - e. Set the calibrator to Operate mode (OPR).
 - f. Call and configure the NI 9214 adjustment function according to Table 9.

Table 9. Voltage Adjustment Configuration

| Physical Channel | Reference Value |
|------------------|---|
| cDAQ1Mod8/aix | A reference value from the array of adjustment points |

- g. Set the calibrator to Standby mode (STBY).
- h. Repeat steps d through g for each calibration voltage in the array.

7. Remove the NI CAL-9214 from the NI 9214.
8. Loosen the captive screws and remove the top cover from the NI CAL-9214.
9. Disconnect the calibrator from the NI CAL-9214.
10. Connect the calibrator to the NI CAL-9214 according to Figure 4.
11. Reinstall the top cover on the NI CAL-9214.
12. Connect the NI CAL-9214 to the NI 9214.
13. Adjust the NI 9214 CJC.
 - a. Call the NI 9214 get C Series adjustment points function to obtain an array of recommended calibration voltages for the NI 9214.
 - b. Set the calibrator to a reference value determined by the array of adjustment points.
 - c. Set the calibrator to 2-Wire Compensation mode.
 - d. Set the calibrator to Operate mode (OPR).
 - e. Call and configure the NI 9214 adjustment function according to Table 9.

Table 10. Voltage Adjustment Configuration

| Physical Channel | Reference Value |
|--------------------|---|
| cDAQ1Mod8/_cjtempx | A reference value from the array of adjustment points |

- f. Set the calibrator to Standby mode (STBY).
 - g. Repeat steps a through f for each calibration voltage in the array.
14. Repeat steps 7 through 13 for each CJC channel on the NI 9214.
15. Close the calibration session.

EEPROM Update

When an adjustment procedure is completed, the NI 9214 internal calibration memory (EEPROM) is immediately updated.

If you do not want to perform an adjustment, you can update the calibration date and onboard calibration temperature without making any adjustments by initializing an external calibration, setting the C Series calibration temperature, and closing the external calibration.

Reverification

Repeat the [Verification](#) section to determine the As-Left status of the device.



Note If any test fails Reverification after performing an adjustment, verify that you have met the [Test Conditions](#) before returning your device to NI. Refer to [Where to Go for Support](#) for assistance in returning the device to NI.

Accuracy Under Calibration Conditions

The values in the following table are based on calibrated scaling coefficients, which are stored in the onboard EEPROM.

The following accuracy table is valid for calibration under the following conditions:

- Ambient temperature $23\text{ }^{\circ}\text{C} \pm 5\text{ }^{\circ}\text{C}$
- NI 9214 installed in slot 8 of an NI cDAQ-9178 chassis
- Slots 1 through 7 of the NI cDAQ-9178 chassis are empty



Note The test limits listed in Tables 4, 5, and 8 are derived using the values in Table 11.

Table 11. NI 9214 Accuracy Under Calibration Conditions

| Mode | PPM of Reading | PPM of Range |
|-----------------|----------------|--------------|
| High Resolution | 440 | 18 |
| High Speed | 600 | 104 |



Note For operational specifications, refer to the most recent *NI 9214 with NI TB-9214 Operating Instructions and Specifications* online at ni.com/manuals.

Where to Go for Support

The National Instruments Web site is your complete resource for technical support. At ni.com/support you have access to everything from troubleshooting and application development self-help resources to email and phone assistance from NI Application Engineers.

National Instruments corporate headquarters is located at 11500 North Mopac Expressway, Austin, Texas, 78759-3504. National Instruments also has offices located around the world to help address your support needs. For telephone support in the United States, create your service request at ni.com/support and follow the calling instructions or dial 512 795 8248. For telephone support outside the United States, visit the Worldwide Offices section of ni.com/niglobal to access the branch office Web sites, which provide up-to-date contact information, support phone numbers, email addresses, and current events.

Refer to the *NI Trademarks and Logo Guidelines* at ni.com/trademarks for more information on National Instruments trademarks. Other product and company names mentioned herein are trademarks or trade names of their respective companies. For patents covering National Instruments products/technology, refer to the appropriate location: **Help»Patents** in your software, the `patents.txt` file on your media, or the *National Instruments Patents Notice* at ni.com/patents. You can find information about end-user license agreements (EULAs) and third-party legal notices in the readme file for your NI product. Refer to the *Export Compliance Information* at ni.com/legal/export-compliance for the National Instruments global trade compliance policy and how to obtain relevant HTS codes, ECCNs, and other import/export data.

© 2012–2013 National Instruments. All rights reserved.