

NI 9217 Calibration Procedure

[Français](#) [Deutsch](#) [日本語](#) [한국어](#) [简体中文](#)

ni.com/manuals

This document contains information about calibrating the National Instruments 9217 module using NI-DAQmx. This calibration procedure is intended for metrology labs.

This document does not discuss programming techniques or compiler configuration. The NI-DAQmx driver contains online help files that have compiler-specific instructions and detailed function explanations. You can install these help files when you install NI-DAQmx on the calibration computer.

Contents

Conventions	2
Software	2
Documentation	3
Calibration Interval	3
Test Equipment	4
Test Conditions	4
Calibration Procedure	5
Calibration Process Overview	5
Initial Setup	5
Verification Procedure	6
Test Limits	10
Range	10
Test Point	10
1-Year Limits	10
Appendix	11
Where to Go for Support	12

Conventions

The following conventions appear in this manual:

» The » symbol leads you through nested menu items and dialog box options to a final action. The sequence **File»Page Setup»Options** directs you to pull down the **File** menu, select the **Page Setup** item, and select **Options** from the last dialog box.



This icon denotes a note, which alerts you to important information.

bold Bold text denotes items that you must select or click in the software, such as menu items and dialog box options. Bold text also denotes parameter names and hardware labels.

italic Italic text denotes variables, emphasis, a cross-reference, or an introduction to a key concept. Italic text also denotes text that is a placeholder for a word or value that you must supply.

monospace Monospace text denotes text or characters that you should enter from the keyboard, sections of code, programming examples, and syntax examples. This font is also used for the proper names of disk drives, paths, directories, programs, subprograms, subroutines, device names, functions, operations, variables, filenames, and extensions.

monospace italic Italic text in this font denotes text that is a placeholder for a word or value that you must supply.

Software

Install NI-DAQmx 8.5 or later on the calibration computer. NI-DAQmx includes high-level function calls to simplify the task of writing software to calibrate devices. You must have the proper device driver installed on the calibration system before calibrating the device.



Note NI recommends that you install the NI-DAQmx driver software before physically installing the NI 9217. NI-DAQmx, available at ni.com/downloads, configures and controls the NI 9217.

NI-DAQmx supports a number of programming languages, including LabVIEW, LabWindows™/CVI™, Microsoft Visual C++ 6.0, Microsoft Visual Basic 6.0, Microsoft .NET, and Borland C++.

You can access the NI-DAQmx header file, `NIDAQmx.h`, like any standard library. You can find examples of how to use the NI-DAQmx driver in the `Program Files\National Instruments\NI-DAQ\Examples` directory.

Documentation

You might find the following documentation helpful as you write the calibration procedure:

- *NI-DAQmx Help*—This help file contains general information about measurement concepts, key NI-DAQmx concepts, and common applications that apply to all programming environments. To access this help file, select **Start»All Programs»National Instruments»NI-DAQ»NI-DAQmx Help**.
- *NI-DAQmx C Reference Help*—This help file contains C reference and general information about measurement concepts. To access this help file, select **Start»All Programs»National Instruments»NI-DAQ»NI-DAQmx C Reference Help**.
- *DAQ Getting Started Guide* for NI-DAQ 8.0 or later—This guide describes how to install NI-DAQmx for Windows software and NI-DAQmx-supported DAQ devices, and how to confirm that your device is operating properly. To access this guide, select **Start»All Programs»National Instruments»NI-DAQ»DAQ Getting Started Guide**.



Note The documents above are installed with NI-DAQmx. You can also download the latest versions from the NI Web site at ni.com/manuals.

- *NI 9217 Operating Instructions and Specifications* — This document describes how to use the NI 9217 and includes specifications and terminal assignments for the NI 9217. The limits you use to verify the accuracy of this device are based on the specifications found in this document. You can download the latest version of this document from the NI Web site at ni.com/manuals.

Calibration Interval

The NI 9217 should be calibrated at a regular interval as defined by the measurement accuracy requirements of your application. National Instruments recommends that you routinely perform a complete calibration at least once every year. You can shorten this interval based on the accuracy demands of your application or requirements of your processes.

Test Equipment

National Instruments recommends that you use the following equipment for calibrating the NI 9217.

Table 1. Recommended Equipment

Equipment	Recommended Model	Requirements
DMM	NI 4070	If this instrument is unavailable, use a multiranging 6 1/2 digit DMM with an accuracy of at least 90 ppm.
Precision resistors	0 Ω , 100 Ω , 350 Ω *	You must use resistors that are <10 ppm/°C or better.
Chassis	NI cDAQ-9172	—
Connection accessory	NI 9939	—

*These are approximate values. Use resistor values as close to 100 Ω and 350 Ω as possible. For the 0 Ω resistor, use a short piece of wire.

Test Conditions

Follow these guidelines to optimize the connections and the environment:

- Keep connections to the device as short as possible. Long cables and wires act as antennae, picking up extra noise that can affect measurements.
- Use shielded copper wire for all cable connections to the device. Use twisted-pair wire to eliminate noise and thermal offsets.
- Maintain an ambient temperature of 25 ± 10 °C. The device temperature will be greater than the ambient temperature.
- Keep relative humidity below 80%.
- Allow a warm-up time of at least 10 minutes to ensure that the measurement circuitry is at a stable operating temperature.

Calibration Procedure

This section provides instructions for verifying the performance of the NI 9217.

Calibration Process Overview

The calibration process consists of the following steps:

1. *Initial Setup*—Configure the device in NI-DAQmx.
2. *Verification Procedure*—Verify the existing operation of the device. This step confirms whether the device is operating within its specified range and whether it needs adjustment.
3. *Adjustment*—If the device does not fall within the desired specifications, submit the device to NI for a factory calibration to adjust the calibration constants.
4. *Verification Procedure*— Perform another verification to ensure that the device operates within its specifications after adjustment.

The first two steps are explained in the following sections.

Initial Setup

You must configure the device in Measurement & Automation Explorer (MAX) to communicate with NI-DAQmx.

Complete the following steps to configure a device in MAX:

1. Install the NI-DAQmx driver software.
2. Make sure that no power is connected to the module terminals. If the system is in a nonhazardous location, the chassis power can be on when you install the module.
3. Insert the module into an available slot in the cDAQ-9172 chassis.
4. Launch MAX.
5. Right-click the device name and select **Self-Test** to ensure that the device is working properly.



Note When a device is configured with MAX, it is assigned a device name. Each function call uses this device name to determine which DAQ device to calibrate. This document uses `dev1` to refer to the device name. In the following procedures, use the device name as it appears in MAX.

Verification Procedure

Verification determines how well the device is meeting its specifications. By completing this procedure, you can see how the device has drifted over time, which helps you determine the appropriate calibration interval for your application. Table 2 in the *Test Limits* section shows all acceptable settings for the device type. Throughout the verification process, use Table 2 to determine if the device is operating within its specified range.

Complete the following steps to test the performance of the device:

1. Acquire a 4-wire resistance measurement of each resistor (0 Ω , 100 Ω , 350 Ω) with a DMM. You must use the 4-wire resistance measurements to calculate the 1-Year Limits shown in Table 2. The Test Point Value in Table 2 refers to the 4-wire resistance measurement of each resistor with a DMM.
2. Connect a resistor from the previous step to the NI 9217. Connect EX0 and RTD0+ to one end of the resistor, and RTD0- and COM to the opposite end of the resistor. Refer to Figure 1 for the terminal assignments of the NI 9217.

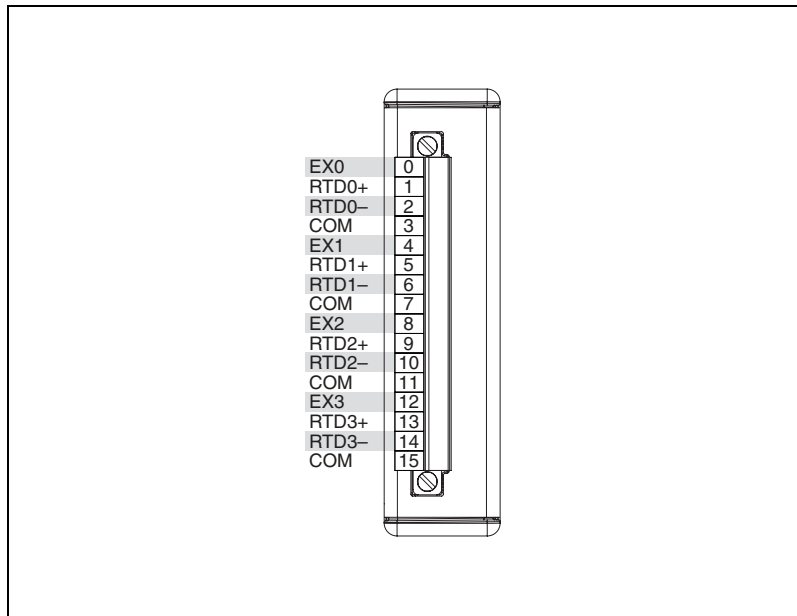

Figure 1. NI 9217 Terminal Assignments

- If you use C function calls, create a task using `DAQmxCreateTask`, as shown in the following table. If you use LabVIEW, skip this step. The task is created in step 4 in LabVIEW.

LabVIEW Block Diagram	NI-DAQmx Function Call
<p>LabVIEW does not require this step.</p>	<p>Call <code>DAQmxCreateTask</code> with the following parameters:</p> <p>taskName: <code>AIVerificationTask</code></p> <p>taskHandle: <code>&taskHandle</code></p>

- Create and configure an AI resistance channel using the DAQmx Create Virtual Channel VI, as shown in the following table. Use Table 2 to determine the minimum and maximum values for the device.



Note Throughout the procedure, refer to the NI-DAQmx function parameters for the LabVIEW input values. Refer to the block diagram images for the correct instance to use for polymorphic VIs.

LabVIEW Block Diagram	NI-DAQmx Function Call
	<p>Call <code>DAQmxCreateAIResistanceChan</code> with the following parameters:</p> <p>taskHandle: <code>taskHandle</code></p> <p>physicalChannel: <code>dev1/ai0</code></p> <p>nameToAssignToChannel: <code>myResistanceChannel</code></p> <p>resistanceConfig: <code>DAQmx_Val_4Wire</code></p> <p>minVal: <code>0</code></p> <p>maxVal: <code>400</code></p> <p>units: <code>DAQmx_Val_Ohms</code></p> <p>customScaleName: <code>NULL</code></p> <p>currentExcitSource: <code>DAQmx_Val_Internal</code></p> <p>currentExcitValue: <code>0.001</code></p>

- Configure the timing properties for the resistance acquisition using the DAQmx Timing VI, as shown in the following table.

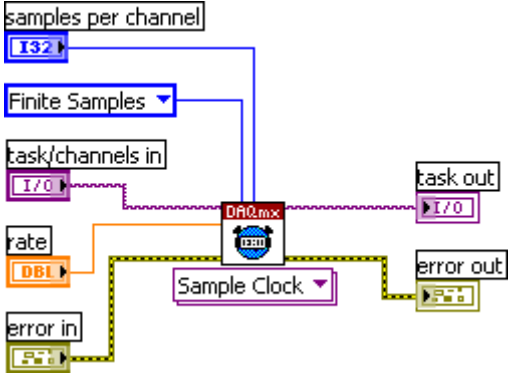
LabVIEW Block Diagram	NI-DAQmx Function Call
	<p>Call DAQmxCfgSampClkTiming with the following parameters:</p> <p>taskHandle: taskHandle source: NULL rate: 1 activeEdge: DAQmx_Val_Rising sampleMode: DAQmx_Val_FiniteSamps sampsPerChan: 10</p>

- Start the acquisition using the DAQmx Start Task VI, as shown in the following table.

LabVIEW Block Diagram	NI-DAQmx Function Call
	<p>Call DAQmxStartTask with the following parameter:</p> <p>taskHandle: taskHandle</p>

- Acquire 10 points of resistance data using the DAQmx Read VI, as shown in the following table.

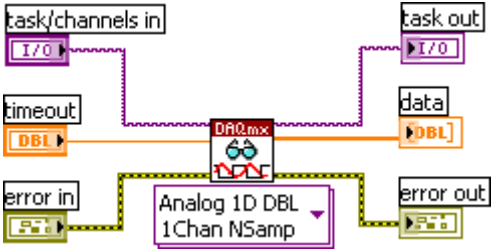
LabVIEW Block Diagram	NI-DAQmx Function Call
 <p>The diagram shows a DAQmx Read VI block. It has three input terminals: 'task/channels in' (I/O), 'timeout' (DBL), and 'error in' (Error). It has three output terminals: 'task out' (I/O), 'data' (DBL), and 'error out' (Error). The 'task/channels in' terminal is connected to a 'task/channels in' control box. The 'timeout' terminal is connected to a 'timeout' control box. The 'error in' terminal is connected to an 'error in' control box. The 'task out' terminal is connected to a 'task out' control box. The 'data' terminal is connected to a 'data' control box. The 'error out' terminal is connected to an 'error out' control box. The DAQmx Read VI block is configured with 'Analog 1D DBL' and '1Chan NSamp'.</p>	<p>Call DAQmxReadAnalogF64 with the following parameters:</p> <p>taskHandle: taskHandle numSampsPerChan: -1 timeout: 30.0 fillMode: DAQmx_Val_GroupByChannel readArray: data arraySizeInSamples: 10 sampsPerChanRead: &read reserved: NULL</p>

- Average the resistance values that you acquired. Compare the resulting average to the Upper Limit and Lower Limit values in Table 2. If the result is between these values, the device passes the test.
- Clear the acquisition using the DAQmx Clear Task VI, as shown in the following table.

LabVIEW Block Diagram	NI-DAQmx Function Call
 <p>The diagram shows a DAQmx Clear Task VI block. It has two input terminals: 'task in' (I/O) and 'error in' (Error). It has one output terminal: 'error out' (Error). The 'task in' terminal is connected to a 'task in' control box. The 'error in' terminal is connected to an 'error in' control box. The 'error out' terminal is connected to an 'error out' control box. The DAQmx Clear Task VI block is configured with 'task in' and 'error in'.</p>	<p>Call DAQmxClearTask with the following parameter:</p> <p>taskHandle: taskHandle</p>

- Repeat steps 2 through 9 for all resistance values and all channels.

Test Limits

Table 2 lists the specifications that the NI 9217 should meet if it has been one year between calibrations. The following definitions describe how to use the information from Table 2.

Range

Range refers to the minimum or maximum resistance range of an input signal.

Test Point

The *Test Point* is the resistance value that is input or output for verification purposes. This value is broken down into two columns—*Location* and *Value*. *Location* refers to where the test value fits within the test range. *Value* refers to the resistance value to be verified. *Max* refers to maximum value, *Min* refers to minimum value, and *Mid* refers to mid-scale.

1-Year Limits

The *1-Year Limits* column contains the *Upper Limits* and *Lower Limits* for the test point value, and an *Error* column to help calculate the limits. When the device is within its 1-year calibration interval, the test point value should fall between these upper and lower limit values.

Table 2. NI 9217 Verification Test Limits

Range (Ω)		Test Point		1-Year Limits*		
Min	Max	Location	Value (Ω) [†]	Error	Lower Limit (Ω) [‡]	Upper Limit (Ω) [‡]
0	400	Max	$DMM_{350\Omega}$	$ DMM_{350\Omega} - 100\Omega \times 175 \text{ ppm} + 16 \text{ m}\Omega$	$DMM_{350\Omega} - Error_{350\Omega}$	$DMM_{350\Omega} + Error_{350\Omega}$
0	400	Mid	$DMM_{100\Omega}$	$ DMM_{100\Omega} - 100\Omega \times 175 \text{ ppm} + 16 \text{ m}\Omega$	$DMM_{100\Omega} - Error_{100\Omega}$	$DMM_{100\Omega} + Error_{100\Omega}$
0	400	Min	$DMM_{0\Omega}$	$ DMM_{0\Omega} - 100\Omega \times 175 \text{ ppm} + 16 \text{ m}\Omega$	$DMM_{0\Omega} - Error_{0\Omega}$	$DMM_{0\Omega} + Error_{0\Omega}$

* The 1-Year Limits are accurate assuming you have performed the verification procedure at an ambient temperature of 25 ± 10 °C. Verification of the module against the 1-Year Limits guarantees operation within the range of -40 to 70 °C as specified in the NI 9217 Operating Instructions and Specifications.

[†] You must read this value using a DMM with the accuracy requirements displayed in Table 1.

[‡] Use the 25 ± 10 °C maximum gain error of 175 ppm and maximum offset error of 16 m Ω to calculate the lower and upper limits.

Appendix

You can convert the resistance values into temperature values using the Callendar Van Dusen equations and common 100 Ω platinum RTD constants.

Temperatures below 0 °C:

$$R_T = R_0[1 + A \times T + B \times T^2 + C \times T^3 \times (T - 100 \text{ °C})]$$

Temperatures above 0 °C:

$$R_T = R_0(1 + A \times T + B \times T^2)$$

where T = temperature in degrees Celsius

R_T = RTD resistance at temperature T

R_0 = RTD nominal resistance at 0 °C. For the NI 9217, R_0 is always equal to 100 Ω .

$$A = 3.9083 \times 10^{-3}$$

$$B = -5.775 \times 10^{-7}$$

$$C = -4.183 \times 10^{-12}$$

Where to Go for Support

The National Instruments Web site is your complete resource for technical support. At ni.com/support you have access to everything from troubleshooting and application development self-help resources to email and phone assistance from NI Application Engineers.

National Instruments corporate headquarters is located at 11500 North Mopac Expressway, Austin, Texas, 78759-3504. National Instruments also has offices located around the world to help address your support needs. For telephone support in the United States, create your service request at ni.com/support and follow the calling instructions or dial 512 795 8248. For telephone support outside the United States, contact your local branch office:

Australia 1800 300 800, Austria 43 662 457990-0,
Belgium 32 (0) 2 757 0020, Brazil 55 11 3262 3599,
Canada 800 433 3488, China 86 21 5050 9800,
Czech Republic 420 224 235 774, Denmark 45 45 76 26 00,
Finland 358 (0) 9 725 72511, France 01 57 66 24 24,
Germany 49 89 7413130, India 91 80 41190000, Israel 972 3 6393737,
Italy 39 02 41309277, Japan 0120-527196, Korea 82 02 3451 3400,
Lebanon 961 (0) 1 33 28 28, Malaysia 1800 887710,
Mexico 01 800 010 0793, Netherlands 31 (0) 348 433 466,
New Zealand 0800 553 322, Norway 47 (0) 66 90 76 60,
Poland 48 22 3390150, Portugal 351 210 311 210, Russia 7 495 783 6851,
Singapore 1800 226 5886, Slovenia 386 3 425 42 00,
South Africa 27 0 11 805 8197, Spain 34 91 640 0085,
Sweden 46 (0) 8 587 895 00, Switzerland 41 56 2005151,
Taiwan 886 02 2377 2222, Thailand 662 278 6777,
Turkey 90 212 279 3031, United Kingdom 44 (0) 1635 523545

National Instruments, NI, ni.com, and LabVIEW are trademarks of National Instruments Corporation. Refer to the *Terms of Use* section on ni.com/legal for more information about National Instruments trademarks. Other product and company names mentioned herein are trademarks or trade names of their respective companies. For patents covering National Instruments products, refer to the appropriate location: **Help»Patents** in your software, the `patents.txt` file on your CD, or ni.com/patents.